

# Inner compact Devices

## *compact devices*

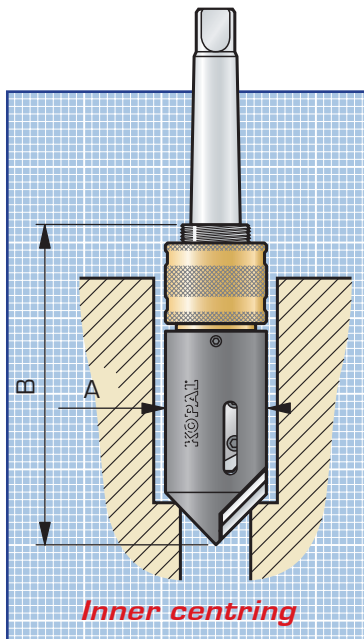

Model	Ø	
	A	B
<b>3-19</b>	19,5	68 / 78
<b>4-30</b>	32	103
<b>10-30</b>	32	100/112
<b>4-42</b>	44	135

### Inner blades replacement

#### SLIM LINE

**HSS blade 60°** Ref.

3 - 19	03-310
10 - 3	03-305

**HSS blade 90°**

3 - 19	03-320
4 - 30	03-325
4 - 42	03-350
10 - 30	03-300

**Carbide blade 90°**

4 - 42	01-351
--------	--------

The inner HSS blades are sharpened with cutting angles of :  
**0° - 14° - 20° and 25° , to be specified on ordering.**

Carbide blades with cutting angle of 0°.

Model	Diameter of the chamfering	Attach.	Angle of the chamfer tip	
			60° Ref.	90° Ref.
<b>3 - 19</b>	3 to 19	Cyl. Ø 10	<b>03-015</b>	<b>03-010</b>
		SW 6.35 mm		<b>03-011</b>
<b>4 - 30</b>	4 to 31	Weldon Ø 16		<b>03-016</b>
<b>10 - 30</b>	11 to 31	CM1	<b>03-035</b>	<b>03-020</b>
		CM2	<b>03-036</b>	<b>03-021</b>
		Cyl. Ø 12	<b>03-040</b>	<b>03-025</b>
<b>4 - 42</b>	5 to 41	CM2		<b>03-051</b>
		Weldon Ø 20		<b>03-053</b>
		Cyl. Ø 12.7		<b>03-055</b>



**Blades**  
 1 cutting edge for small models 3-19.  
 All the other models have 2 cutting edges.

